

## 4.6 Losses in Electrical Networks

### *Losses in electrical networks means:*

- Financial losses
    - undelivered energy
    - outage costs of the customer
  - Non-technical losses
    - energy theft
      - hardware connection before the meter; without a meter
      - meter manipulation
      - electro-magnetic coupling: inductive or capacitive
  - Technical losses
    - in the power plants
      - auxiliary system
    - in the networks
      - all copper or aluminium conductors have an real ohmic resistance;
      - $R = f$  (cross-section, material, length, temperature)
- $R = U/I$ ;     $I^2 \cdot R = \underline{U \cdot I} = P_V$      $E = \sum_t P_{Vi} \cdot \Delta t \rightarrow$  additional generator
- inductive or capacitive currents produce losses in ohmic resistances
  - dielectric losses ( temperature, voltage dependent; insulating material )
  - hysteresis ( magnetic, electric field; transformer sheet/lamination )
  - corona or partial discharges of UHV/HV components
  - measuring the losses
    - meters on both sides of an element (transformer)
    - direct measuring the element with a Watt-meter
  - estimating losses of transformers (MV/LV)
    - Fe-losses (magnetic field in the iron sheets) proportional to U (small variation)
    - Cu-losses proportional  $I^2$  ( great variation)
    - approximation by calculation program with actual  $I_{max}$  inputs
  - calculation losses
    - meter difference of injected and delivered energy
  - load flow calculation in HV networks
  - inaccuracy
    - energy meter and ct/pt have fault !!
    - meter tolerances to high with preference towards high or low
    - equivalent circuit data are not correct
    - voltage and load curve dependence not sufficient considered
    - wrong meter constant

➤ **valuation of technical losses** (compare chapter 2.5)

➤ **strategies to reduce losses**

- line losses → optimised cross-section of conductors;  
compensation of capacitive current  
network adaptation  
no corona (aging, surface, humidity, temperature)
- transformers → optimised transformer (power, losses, costs)  
adaptation (higher load ↔ switching off low loaded ones)  
exchange of transformers with such ones with grain orientated lamination (poor losses)

customers → compensation of capacitive/inductive load

general →

MV/LV transformers, MV network, HV/MV transformers, HV network, power plants (injection points)  
increasing the MV in the allowed limits (IEC:  $380 \pm 6\%$ )

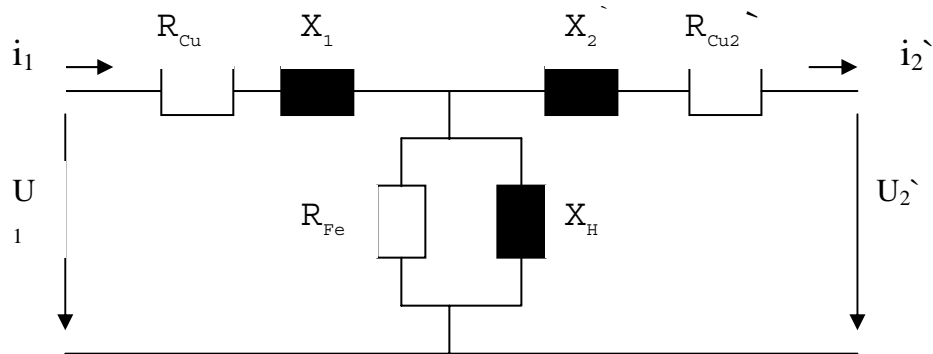

Transformer equivalent diagram

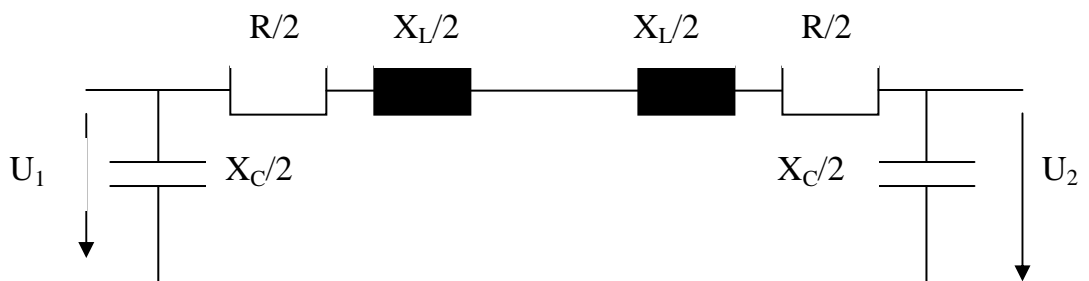

OHL equivalent diagram

## Valuation of energy losses

Annual load duration curve

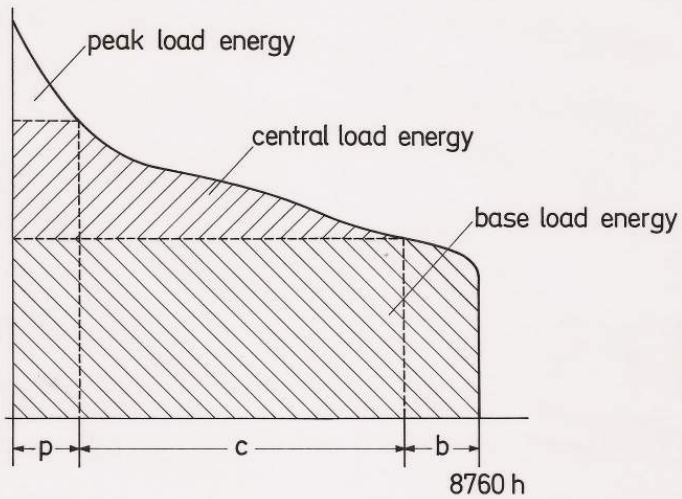

value of energy losses :

during  $p$  : price of peak load energy

$c$  : price of central load energy

$b$  : price of base load energy